



Meridian

deep down you want the best

scubapro.com

MERIDIAN DIVING COMPUTER - DESIGNED BY DIVERS

Welcome to SCUBAPRO dive computers and thank you for purchasing the Meridian. You are now the owner of an extraordinary partner for your dives. This manual provides you easy access to SCUBAPRO state of the art technology and Meridian's key features and functions. Should you wish to know more about SCUBAPRO diving equipment, please visit our website www.scubapro.com.

WARNING

- Meridian has a depth rating of 120m/394ft.
- If 120m is exceeded, -- will be shown in the depth field and the decompression algorithm does not calculate correctly.
- Diving at oxygen partial pressures higher than 1.6 bar (corresponding to a depth of 67m/220ft when breathing compressed air) is extremely dangerous and could lead to serious injury or death.



Meridian dive instrument is a personal protective equipment in compliance with the essential safety requirements of the European Union directive 89/686/EEC. RINA SpA, Via Corsica 12, I-16128 Genoa, notified body no. 0474, have certified the conformity with the European Standard EN 13319:2000.

EN13319:2000 Diving accessories - Depth gauges and combined depth and time measuring devices - Functional and safety requirements, test methods. Any information on decompression obligation displayed by equipment covered by this standard is explicitly excluded from its scope.

TABLE OF CONTENTS

1. Introduction to Meridian	6
1.1 Battery	6
2. Meridian as a watch	8
2.1.1 Setting the alarm clock	12
2.1.2 Setting the UTC	12
2.1.3 Setting the time	12
2.1.4 Set the 12/24h mode	13
2.1.5 Setting the date	13
2.1.6 Setting the sound to “off” (silent mode)	13
2.1.7 Checking the battery status	14
2.1.8 Checking the device ID	15
2.1 Menus and functions	16
2.1.1 Using the Stopwatch	17
2.1.2 Checking the Altitude	17
2.1.3 Planning a dive	18
2.1.4 Reading the Logbook	19
2.1.5 Dive surface mode display	20
3. Meridian as a dive computer	21
3.1 Settings at the dive mode	21
3.1.1 Dive mode at surface	23
3.1.2 Surface interval counter	23
3.2 Gas settings	23
3.2.1 Set Gas 1	23
3.2.2 Set Gas 2	24
3.2.3 Nitrox reset time	24
3.2.4 Workload settings (pulse limits)	25
3.2.5 Desaturation reset	25
3.3 SCUBA settings	25
3.3.1 Maximum dive depth alarm	25
3.3.2 Maximum dive time alarm	26
3.3.3 Setting the Micro Bubble level	26
3.3.4 Setting the Safety stop timer	26
3.3.5 Setting the user preferred units	26
3.3.6 Selecting the salt (ocean) or fresh water	27
3.3.7 Setting the Backlight on duration	27
3.3.8 Setting audible attention signals on and off	27
3.3.9 Deactivating the water contacts	28
3.4 APNEA Settings	28
3.4.1 Setting the dual depth alarm	28
3.4.2 Setting the depth incremental alarm	29
3.4.3 Setting the dive time interval warning	29
3.4.4 Setting the surface interval warning	29
3.4.5 Setting the low Heart Rate limit alarm	29
3.4.6 Setting the Ascent speed alarm	30
3.4.7 Setting the water density	30
3.5 Algorithm selection	31

3.6	Diving with Meridian	32
3.6.1	Display information	32
3.6.2	Display configuration during the dive	33
3.7	Altitude diving	34
3.7.1	Altitude classes, altitude warning and no-fly time after a dive ..	34
3.7.2	Altitude and the decompression algorithm	35
3.7.3	Prohibited altitude	35
3.7.4	Decompression dives in mountain lakes	36
3.8	No-dive warning after a dive	36
3.9	SOS	37
3.9.1	Desaturation reset	37
3.10	Diving with nitrox or with another decompression gas	37
3.10.1	Diving with two gas mixtures	38
3.11	Warnings and alarms	40
3.11.1	CNS O ₂ = 75%	40
3.11.2	No-Stop time = 2 minutes	40
3.11.3	Entering decompression	41
3.11.4	Entering level stops	41
3.11.5	L0 no stop time = 2 minutes when diving an MB level	41
3.11.6	Entering deco when diving an MB level	41
3.11.7	Ascent rate	41
3.11.8	MOD/ppO ₂	42
3.11.9	CNS O ₂ = 100%	42
3.11.10	Missed decompression stop	43
3.11.11	Low battery	43
3.11.12	Setting bookmarks	43
3.11.13	Safety stop timer	43
3.11.14	Activating the backlight	44
3.11.15	Diving with MB levels	44
3.11.16	Display information	45
3.11.17	Display of underlying L0 decompression information	46
3.11.18	Cascading MB levels	46
3.11.19	Level stop ignored/MB level reduced	46
3.11.20	PDI Stops	46
3.12	GAUGE mode	47
3.13	APNEA mode	49
4.	Meridian accessories	50
4.1	HR belt	50
4.2	Nylon arm strap	50
5.	Meridian PC interface	51
5.1	Cradle	51
5.2	Introduction to SCUBAPRO LogTRAK	51
5.2.1	Download dive profiles	51
5.2.2	Change warnings/settings of the Meridian and reading dive computer info	52

6. Taking care of Meridian	53
6.1 Technical information	53
6.2 Maintenance	53
6.3 Replacing the battery in Meridian	54
6.4 Warranty	55
7. Glossary	56
8. Index	58

1. INTRODUCTION TO MERIDIAN

The Meridian User Manual is divided into the following main sections.

1 Introduction to Meridian. This section provides an overview of the Meridian dive computer and describes its operating modes and functions when on the surface.

2 Meridian as a watch. This section describes Meridian when it is used as a watch.

3 Meridian as a dive computer. This section describes all settings and functions of Meridian as a dive computer and takes you underwater with Meridian. It's about everything Meridian can and will do to enhance your safety and fun underwater.

4 Meridian accessories. This section briefly describes the Meridian extras that can be purchased as additional options, to get the most from your dive computer in all diving conditions.

5 Meridian PC interface. This section is about personalization and customization. It describes how to change settings, to download and manage your logbook.

Meridian is a technologically-advanced instrument that can accompany you during your underwater adventures while providing you with accurate depth, time and decompression information. On the surface its size and good looks makes it an ideal everyday watch. With features such as wake-up alarm, stop watch, and altimeter, Meridian can handle almost every task in your daily activities.



The buttons allow you to operate functions, access menus and change settings while on the surface. During the dive buttons set bookmarks, show additional information on the dive computer screen and activate the backlight.

We hope you will enjoy getting to know your new dive computer and we wish you many wondrous dives with the Meridian.

1.1 Battery

Meridian uses a CR2032 lithium battery, available from your authorized SCUBAPRO dealer. To reduce the risk of fire or burns, follow the battery manufacturers recommendations when replacing, recycling or disposing the battery. Meridian will alert you when the battery is approaching a critical value by displaying the battery symbol. In addition, you can verify the status of the battery on the main menu.

When the battery symbol appears, this means that the battery is in fact low, although with some reserve remaining. In dive mode the backlight will not activate or work when the battery is low and the battery symbol is shown. If the battery symbol flashes the battery level is dangerously low and neither the backlight nor the alarm tones will be activated, and therefore diving

is not recommended before changing the battery.



Battery symbol

⚠ WARNING

Starting a dive when the battery symbol is flashing can cause the dive computer to fail during the dive! Replace the battery before any diving activity if the flashing battery symbol appears.

When the 'do not dive symbol' appears with the battery symbol, Meridian can not be used for diving before replaced with a new battery.

⊘ Do not dive symbol

Please refer to chapter **2.1.7 Checking the battery status** for details how to check your Meridian battery status.

⚠ WARNING

Replacing the battery requires opening the electronic compartment of Meridian. You must take extreme care when performing the battery change operation in order to ensure the water seal of the watch. Failing to do so will cause Meridian to flood during your next dive and permanently damage the dive computer. Damage to Meridian due to an improper battery replacement is not covered by warranty. We strongly recommend having the battery change operation be carried out by your authorized SCUBAPRO dive retailer.

See chapter **6.3 Replacing the battery in Meridian** for more information on how to replace the battery.

2. MERIDIAN AS A WATCH

Meridian is more than just a watch. It features:

- a wake-up alarm-clock function
- a stopwatch with lap time and 99 hours run time
- an altimeter for tracking excursions to the mountains.
- a thermometer

NOTE: Considering that the metal housing is a good heat conductor, the temperature reading will be warmer than reality when wearing Meridian directly on the wrist exposed to your skin. This does not happen underwater as usually it is worn over a wetsuit.

The functions of the buttons when on the surface are summarized in the table below and explained in detail in the following sections.



Button LIGHT, Top Left : Short press = backlight

Button +/UP, Top Right: +/UP = adds numerical values, scrolls up in the menus

Button -/DOWN, Bottom Right: -/DOWN = subtracts numerical values, scrolls down in the menus

Button SEL/ESC, Bottom Left:

- Short press = select,
- Long press = escape (return to previous menu) or
- cancel the setting

The diagram below shows the watch menu logic in a graphic form. The diving functions are described in detail in section **3 Meridian as a dive computer**.

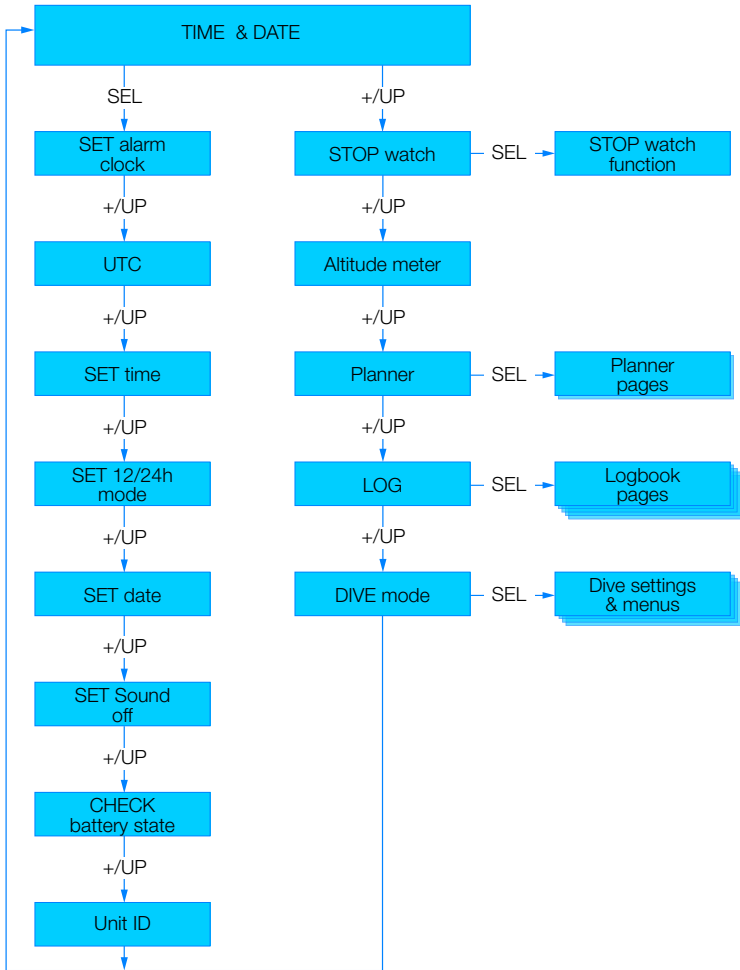

2. Meridian as a watch

The reference point for any description of Meridian as a watch is the main **time of day** display. This is the display in which the current time is shown in the middle row. The upper display row shows the date. For example the diagram below shows Saturday, 23rd of November and the time is one second past 10 o'clock.



24h mode



12h mode

Clock setting functions

By pressing the SEL/ESC button from the main time and date display you will get into **clock settings** (marked dark at the graphics below).

By pressing +/UP button you scroll to the next menu. By pressing SEL/ESC button

you may edit the settings and values on that current menu.

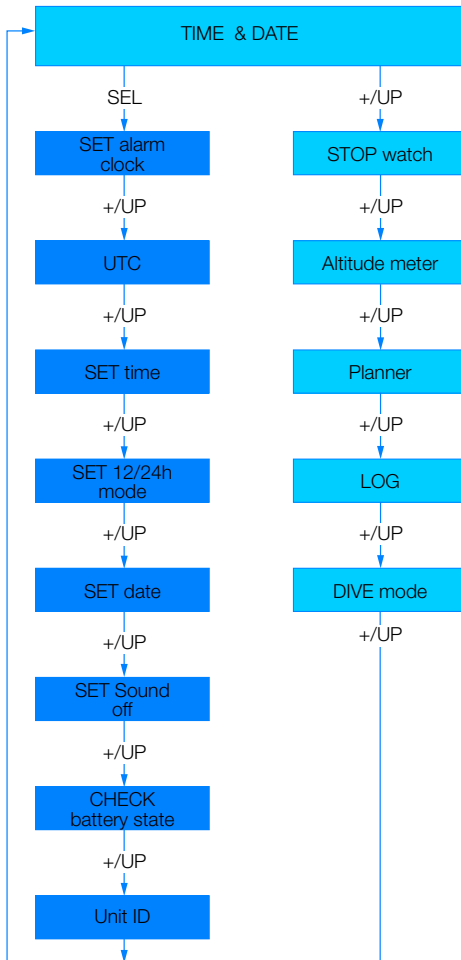

2.1.1 Setting the alarm clock



Alarm off

By pressing the SEL/ESC button the alarm time will start flashing.

You can scroll the hours setting by pressing +/UP or -/DOWN buttons.

By again pressing the SEL/ESC button the minutes will start flashing and by pressing +/UP or -/DOWN buttons you can scroll them.

By again pressing the SEL/ESC button the state of alarm will start flashing and 'on' or 'off' can be selected by pressing +/UP or -/DOWN buttons.

Pressing the SEL/ESC button again at the end will confirm the alarm time settings.

NOTE: Setting the sound setting to 'off' does not affect the alarm clock. However, the intelligent battery stretching algorithm disables all warning tones when there are two or less dots remaining on the battery status display or when the battery symbol is flashing in another display.

2.1.2 Setting the UTC

UTC setting will change the shown time compared to Greenwich 0-Meridian. This feature is practical when travelling through different time zones.

By pressing SEL at UTC menu, the hours will start to flash. You may edit them with +/UP or -/DOWN buttons. By pressing SEL the minutes will start to flash and you may edit them with +/UP or -/DOWN buttons in 15 minutes increments. Activate the UTC setting by pressing SEL.



2.1.3 Setting the time



Setting the current time

In the display above the current time is displayed on the menu. By pressing the SEL/ESC button, the time setting will be activated: hours start flashing and seconds will turn to 00. You may change the hours with +/UP or -/DOWN buttons. By pressing the SEL/ESC button the selection will change to minutes and you may now edit them. By pressing the SEL/ESC the new time setting will be saved.

NOTE: seconds cannot be edited; they always start counting from 0.

2.1.4 Set the 12/24h mode

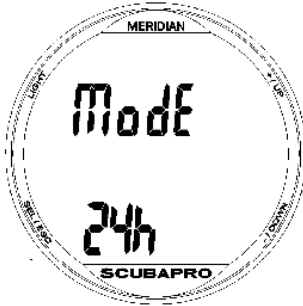

24 hour display

By pressing the SEL/ESC button at the mode menu 24h starts flashing. With +/UP or -/DOWN buttons you may change between 24 hour or 12 hour format = am/pm displays. Pressing SEL/ESC will save the selection.

NOTE: the 12 hour selection will change the shown day format to display date in the following sequence: Month.Date.Year. If you keep the watch in the 24 hour format, you will have the date displayed in the following sequence: Date.Month.Year. This change also takes place in the watch and in the dive computer log book.

2.1.5 Setting the date



When setting the date, by pressing the SEL/ESC button, the first digits will flash, indicating they can be changed by pressing +/UP or -/DOWN buttons (in 24h mode the first digit is days, in 12h mode the first digit

is the month). By pressing the SEL/ESC button the setting will be saved and move to the next digits. Again by pressing the SEL/ESC button the year digits after the dot will start flashing.

2.1.6 Setting the sound to "off" (silent mode)



By pressing the SEL/ESC button the 'on' setting will start flashing at the bottom of the display. By pressing +/UP or -/DOWN buttons you may select 'on' or 'off' for the Meridian silent mode for alarms and button tones. The sound off selection is protected with a code.

⚠ WARNING

The Sound 'off' selection will disable all audible dive mode alarms and warnings. This is potentially dangerous.

NOTE: the only exception to the silent operation is the alarm clock. It will remain activated even if the main setting is: sound off.

To turn off the sound a code must be entered into the dive computer to activate the change. The unlock code for 'sound off' is 313. When the sound off option has been selected the first digit starts flashing. By pressing +/UP or -/DOWN buttons the code number can be changed and by pressing the SEL/ESC button the code number will be stored.



2.1.7 Checking the battery status



Battery status

The battery status menu displays how much energy is left in the CR2032 battery. A brand new battery shows 5 dots.

Meridian periodically measures the battery status and you can manually trigger this display by pressing the SEL/ESC button in the battery status menu.

The intelligent battery algorithm will limit some functions when the battery is close to running out. See the table below for battery status and function details.

Battery status display in battery mode	Display in other modes	Battery status	Function limitations
00000		Fresh battery	none
0000		Battery ok for diving	none
000		Battery ok for diving	none
oo change	Battery symbol	Weak battery, change battery	Backlight not operating
o change	Flashing battery symbol, no dive symbol	Completely used battery, must change	Alarms and Backlight not operating, diving not recommended
None, change	Flashing battery symbol, no dive symbol	Completely used battery, must change, watch may reset at any time and remain off	Diving mode not allowed, only watch may be active

 **NOTE:** The battery capacity and voltage at the end of the battery lifetime may vary depending on battery manufacturers. Generally, operation at low temperatures decreases the battery capacity. Therefore, when the battery indicator drops below 3 dots, change the battery before making any dives.

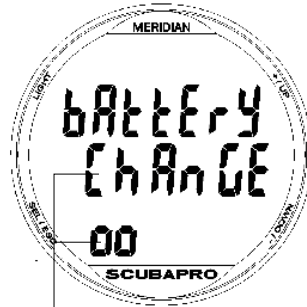

Change the battery before the next dive

2.1.8 Checking the device ID

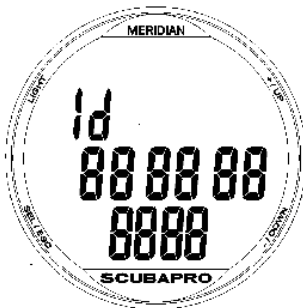

Each Meridian watch has a specific, individual ID number. The 10 digit ID number is shown in this menu.

2.1 Menus and functions

By simply **pressing** buttons +/UP or -/DOWN from the **time of day display** you can scroll through the various menus in Meridian. The diagram below shows the sequence of the menus. Note that when you first reach a menu, you are “outside” of it. You must SEL/ESC button to enter the actual menu.

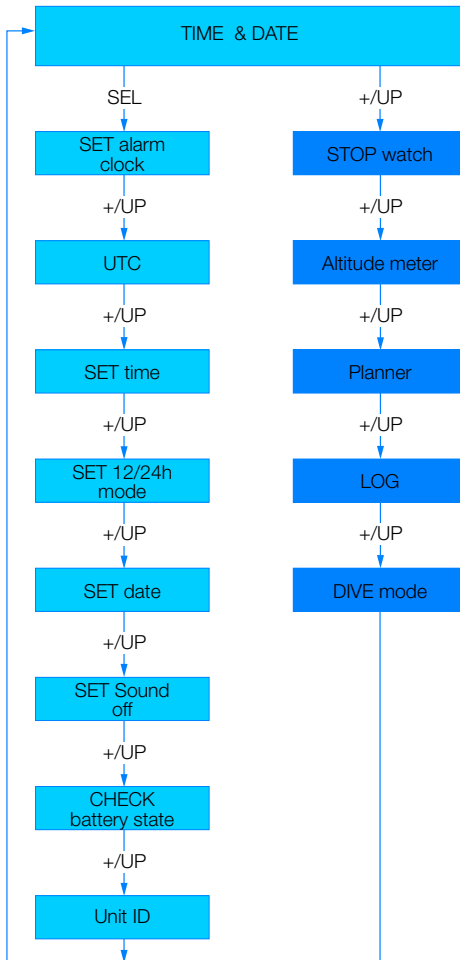

2.1.1 Using the Stopwatch



The first menu from the time of day display is STOP (watch). By pressing SEL/ESC button the stopwatch will be activated.



In the first display the stopwatch shows the status, which can be stop, run or lap. When activating the stopwatch for the first time the display will be as shown above.



Press +/UP button and the stopwatch starts counting showing: run. Press +/UP button again to stop the counting. The counted time will stay on the display. Stopwatch will reset the counted time when +/UP button is pressed and held.

The laps can be marked by pressing -/DOWN button when stopwatch is counting. By doing so the display will freeze for 5 seconds and Meridian shows the lap time.



Counting will continue automatically and the lap counter will show the number of laps at the bottom of the screen.

By pressing SEL/ESC button you can exit the stopwatch and return to the stopwatch menu.

 **NOTE:** You can leave the stopwatch actively counting or you can leave the stopped time on the display. The status will be stored in a memory that allows you to continue from the same display the next time.

2.1.2 Checking the Altitude

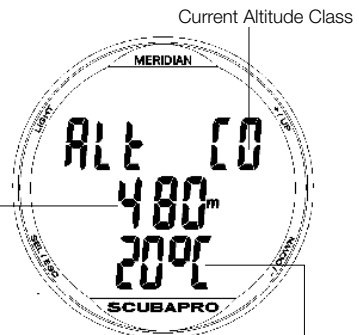

On the altitude menu, the current altitude is calculated from the barometric pressure. The current altitude, the Altitude Class and the temperature are shown.

☞ *NOTE: barometric pressure is a variable, changing with weather and atmospheric pressure at a specific elevation. Dive algorithm uses Altitude Classes which are directly derived from the barometric pressure. Altitude is counted from the current barometric pressure and it is therefore a relative value.*

The altitude can be adjusted when current elevation is known by pressing the SEL/ESC button. The altitude value will start flashing. By pressing +/UP or -/DOWN buttons the value can be adjusted in 10m/50feet increments. Adjusting the altitude elevation has no effect on Altitude Class.

☞ *NOTE: Different altitude/temperature measurement combinations such as m&°C, Ft&°C, m&°F or Ft&°F can be selected from the dive mode menu in: Units.*

2.1.3 Planning a dive

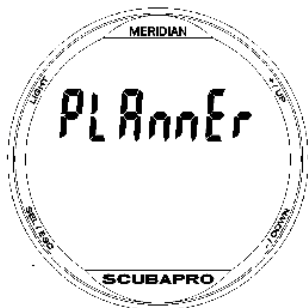

You can plan your next dive based on your body's nitrogen saturation. The planner also uses the following information:

1. Selected oxygen concentration and active tanks
2. Selected water type
3. Selected microbubble level
4. Water temperature of the most recent dive
5. Altitude class
6. Status of saturation at the time the planner is started
7. A normal workload of the diver and observance of the prescribed ascent rates.

By pressing SEL/ESC button at the planner menu you will get into the planner directly or to the surface interval setting (repetitive dive).

☞ *NOTE: When Meridian is in GAUGE or APNEA modes the Planner is disabled and Planner OFF is shown in this menu.*

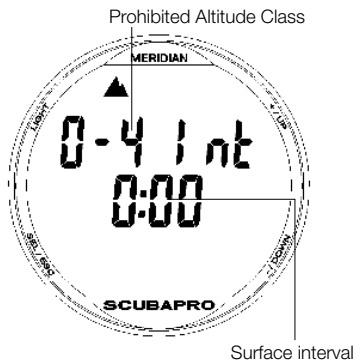

Surface interval

For repetitive dives enter the surface interval: By pressing the +/UP or -/DOWN buttons the surface interval can be adjusted in 15 minutes increments. The prohibited altitude is shown on the top row and by increasing the surface interval the allowed limit will get to maximum (level 4).

In case Meridian is displaying the no-dive warning, the duration of the warning itself is displayed as recommended surface interval for planning purposes (rounded up to the nearest fifteen-minute increment).

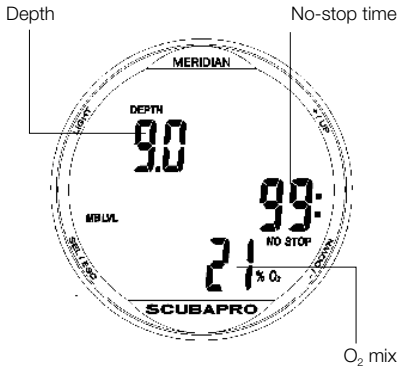

When surface interval is given or if you have no remaining desaturation left, the planner will start flashing the depth. By pressing + or - you can set the depth in 3m/10feet increments.

The No-stop time is shown for that depth at the middle row.

The gas O₂ mix is shown at the bottom row until the 1% CNS for the planned depth has been reached. After that the planner shows the CNS% at bottom row.

Minimum depth for planning is 9m/30feet or MOD of the Gas d (when active).

The planner allows only depths according to maximum ppO₂ given to the Gas 1. The gas oxygen mix and maximum ppO₂ settings are given at the dive mode menu: SET GAS.

⚠ WARNING

If you have set ppO₂max to OFF, the planner will allow depths up to a maximum of 120m/394ft. Air/nitrox dives with high ppO₂ are extremely dangerous and can lead to death. Be aware that exposures to high ppO₂ will lead CNS clock value to exceed maximum recommended 100%.

If Gas 1 MOD is shallower than 9m/30feet, planning is not allowed and information LO ppO₂ is shown.

NOTE: The dive planner considers all programmed gas mixtures

when computing no-stop times or decompression schedules.

By pressing SEL/ESC for planned depth the dive time appears at top row. Start point (minimum now) is the no decompression time. By pressing +/UP or -/DOWN buttons you may change the time in 1 minute increments. When no decompression time is exceeded the planner gives decompression time at the middle row.

By pressing SEL/ESC the planner will exit and you will return to the main menu.

2.1.4 Reading the Logbook

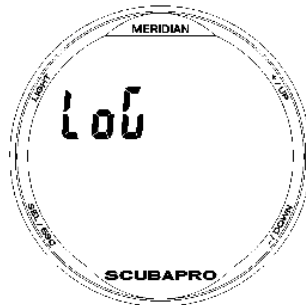

You can check the main information about your dives from the logbook by pressing SEL/ESC in the log menu.

The first page shown is the dive history.

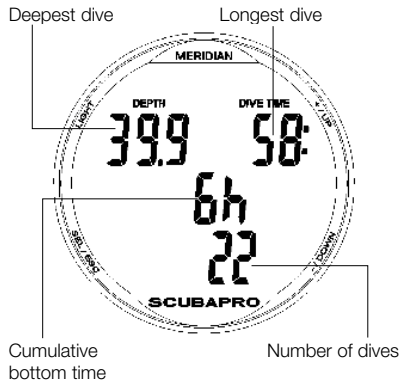

This dive computer history shown above, the deepest dive is 39.9 meters and the longest dive time is 58 minutes. In total,

6 hours of diving and 22 dives have been done with this Meridian.

By pressing +/UP or -/DOWN buttons you can scroll the dives in the memory. In SCUBA mode there is a main page showing maximum depth, dive time, dive date, log number and used Gas 1 oxygen mix.

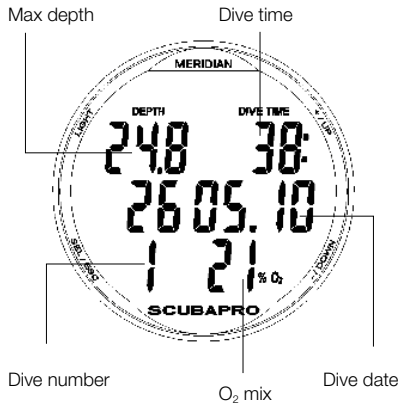

If the dive has been done in GAUGE or APNEA modes, the main page has GA or AP instead of O₂% at the bottom row.

By pressing SEL/ESC you will select the dive and get to the sub display. The information on the display varies depending on the mode of dive:

- Scuba mode: Minimum temperature, dive start time and average heart rate (if enabled).
- APNEA mode: The bottom row will show the maximum ascent rate.
- GAUGE mode: The bottom row will show the average depth.

2.1.5 Dive surface mode display

This display is the starting point of dive functions and sub menus related to underwater options. This is described in detail in the following section **3 Meridian as a dive computer**.

3. MERIDIAN AS A DIVE COMPUTER

Meridian is a full-featured dive computer, capable of multi-gas decompression calculations, ascent rate calculations and warnings. The logbook can store 50 hours of dive profiles with a 4second sampling rate. While diving, it displays depth, dive time, decompression status, water temperature and much more. On the surface, after a dive, it displays remaining desaturation time, no-fly time, surface interval and prohibited Altitude Classes are shown in addition to the watch functions.

3.1 *Settings at the dive mode*

When Meridian is in **surface** mode, you can access various menus dedicated to diving and customize various settings.

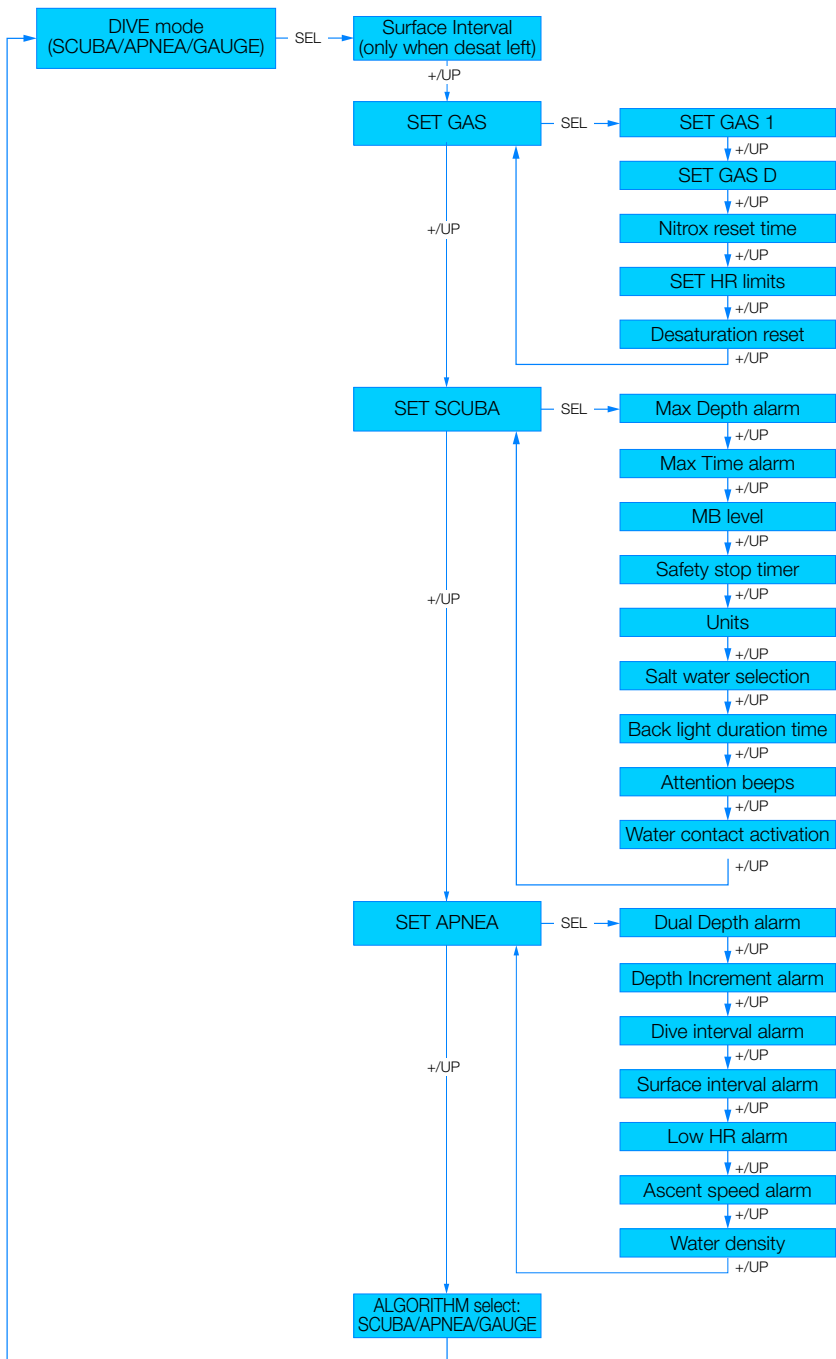

The dive computer functions of Meridian on the surface include, among others, setting the oxygen concentration for nitrox diving, setting the MB level of the decompression algorithm, setting various warnings and personal preferences. To reach any of these functions, Meridian must be in Dive surface mode display. This can be reached pressing the $-$ /DOWN button once from the main time and date display, until text SCUBA, GAUGE or APNEA is shown (after a dive, more information may appear – this is described later in this chapter).

3.1.1 Dive mode at surface

When you have not been diving with your Meridian for a while (no desaturation left) the dive mode may appear as shown below:

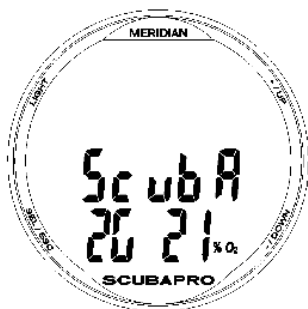

However in SCUBA mode after a dive, the display may appear as shown below:

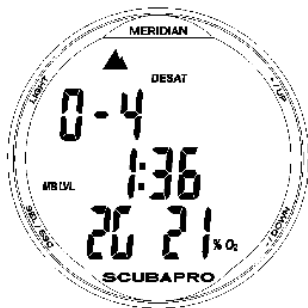

From here (SCUBA mode, after a dive), by **pressing** the SEL/ESC button and scrolling with the $+$ /UP or $-$ /DOWN buttons, you can access a loop of additional menus related to diving, which are: surface interval, set

gas, set scuba, set apnea and algorithm select.

3.1.2 Surface interval counter

After a dive the Meridian shows the surface interval from the latest dive. The surface interval counter counts until desaturation is complete. After the desaturation is complete this menu disappears. The no-fly time is shown at the upper row on the right corner in hours.

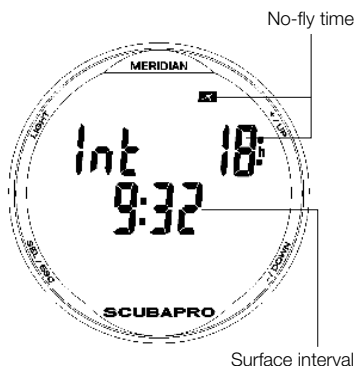

No-fly time

Surface interval

3.2 Gas settings

3.2.1 Set Gas 1

You may use your Meridian with all nitrox mixes from Air to pure oxygen.

By pressing the SEL/ESC button in this display the oxygen mix of Gas 1 starts flashing. By pressing the $+$ /UP or $-$ /DOWN button you may scroll the value from 21 up to 100%.

⚠ WARNING

Diving with a ppO_2 higher than 1.4 is dangerous and may lead to unconsciousness, drowning and death.

By pressing SEL/ESC the maximum partial pressure of oxygen (ppO_2 max) starts flashing. By pressing the $+$ /UP or $-$ /DOWN button you may select the value from 1.00 bar up to 1.60 bar.

NOTE: ppO_2 is fixed to 1.60 bar when selected oxygen fraction is 80% or higher.

Maximum partial pressure of oxygen (ppO_2 max)

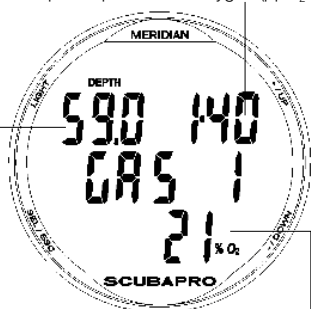

Maximum Operating Depth (MOD)

O₂ mix of Gas 1

It is possible to disable the MOD setting (- - shown at the field), but this requires the security code 313 from the user.



⚠ WARNING

Diving deeper than the MOD is dangerous and may lead to serious injury or death.

By pressing the SEL/ESC button the user will accept the given value.

3.2.2 Set Gas d

When you are planning to make an extended no-stop dive or decompression dive with another mix for accelerated decompression you may set the second gas to active. You may select the Gas d fraction and ppO_2 combination so that the MOD is 3m/10ft deeper than with Gas 1.

By pressing SEL/ESC at this display the oxygen fraction starts to flash. By pressing the +/UP or -/DOWN button you may scroll the value. After accepting it by pressing the SEL/ESC button the maximum partial pressure of oxygen (ppO_2 max) value starts to flash. By pressing +/UP or -/DOWN button the value may be selected from 1.00 bar up to 1.60 bar in 0.05 bar increments.

Maximum partial pressure of oxygen (ppO_2 max)

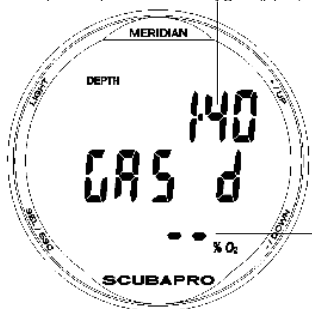

Gas d disabled

Gas d is disabled when - - is shown at %O₂ fractions field.

3.2.3 Nitrox reset time

If you are generally diving with one gas or air only and want to return to this setting after occasional nitrox or multi gas dives, you can preset a default time when your Meridian will reset to air and disable the Gas d.



Gas reset time is disabled when - - h is shown.

3.2.4 Workload settings (pulse limits)

By pressing SEL/ESC button in this menu the Heart Rate (HR) high value starts to flash. By pressing the +/UP or -/DOWN button the value can be changed. By pressing SEL/ESC button the low value starts to flash. By pressing +/- the value can be changed. By pressing SEL/ESC again the mode starts to flash. Possible selections are pulse or off. By pressing SEL/ESC the mode will be entered.

When Pulse is selected then the diving algorithm uses it as an input for the workload. When Off is selected, then the workload is disabled.

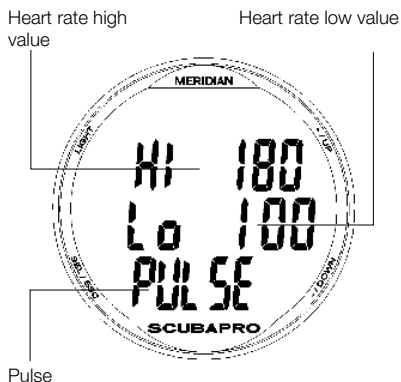

3.2.5 Desaturation reset

⚠ WARNING

Resetting desaturation will effect calculations of the algorithm and this may lead to serious injury or death. Do not reset desaturation without a solid purpose.

When Meridian is still counting down the desaturation, some menu changes are not possible. In case the user decides to reset the desaturation, the safety code 313 must be entered. This procedure secures unwanted resetting and the desaturation reset will be stored in the memory on the next dive log the desaturation symbol will be shown.

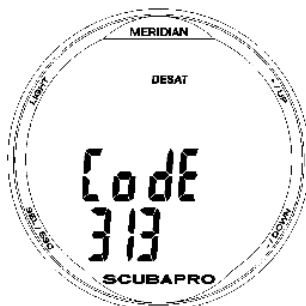

3.3 SCUBA settings

A set of SCUBA related selections are grouped in this menu.



By pressing the SEL/ESC button the following menu's can be scrolled down.

3.3.1 Maximum dive depth alarm

By pressing SEL/ESC button in this menu the depth value starts to flash. By pressing the +/UP or -/DOWN button the value can be selected between 5 and 100 meters (20 to 330 feet) in 1m (5ft) increments.

By pressing SEL/ESC button the function starts to flash and you may select On or Off by pressing the +/UP or -/DOWN button. The selection is confirmed by pressing SEL/ESC button.

Alarm depth

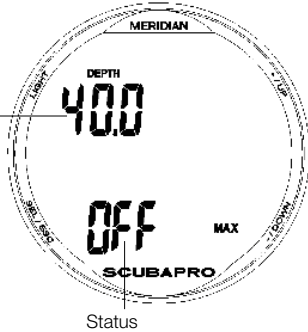

Status

3.3.2 Maximum dive time alarm

By pressing SEL/ESC button in this menu the time value starts to flash. By pressing the +/UP or -/DOWN button the value can be selected between 5 and 195 minutes in 1 minute increments. By pressing SEL/ESC button the function starts to flash and you may select On or Off by pressing the +/UP or -/DOWN button. The selection is confirmed by pressing SEL/ESC button.

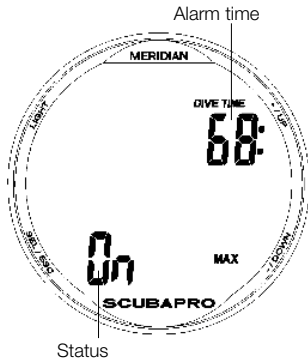

Status

3.3.3 Setting the Micro Bubble level

By pressing SEL/ESC button in this menu the Micro Bubble level starts to flash. By pressing the +/UP or -/DOWN button you may select personal settings from L0 up to

L5. L5 is the most conservative setting. The selection is confirmed by pressing SEL/ESC button.

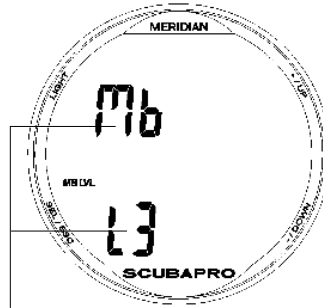

Micro Bubble level

NOTE: more about diving with the MB levels, read chapter: *Diving with MB levels.*

3.3.4 Setting the Safety stop timer

Meridian safety stop timer starts automatically when the depth at the end of the dive becomes less than 5m/15ft and all decompression or MB stops have been accomplished.

By pressing SEL/ESC button at this menu the number at the bottom row will start flashing. By pressing the +/UP or -/DOWN button the value can be set between 1 to 5 minutes or to Off.



Duration of the safety stop

3.3.5 Setting the user preferred units

The user may select between depth and temperature unit combinations. The effect

takes place in dive mode, in the log book, alarm settings, altitude settings etc.



By pressing SEL/ESC button in this menu the style of units field value starts to flash. By the +/UP or -/DOWN button the value can be changed between meters/feet. By pressing SEL/ESC button the temperature field starts to flash. Again by pressing +/- the value may be changed. By pressing SEL/ESC button both unit settings will be confirmed.

3.3.6 Selecting the salt (ocean) or fresh water

Meridian measures a pressure and converts depth from it by using the water density as a constant. 10m/33ft depth at salt water corresponds approximately to 10.3m/34ft at fresh water.



By pressing SEL/ESC button at this menu the on/off field at the bottom row starts to flash. You may scroll between these two settings and confirm by pressing SEL/ESC button.

3.3.7 Setting the Backlight on duration

By pressing SEL/ESC button on this menu the backlight duration field at bottom row starts flashing. By pressing the +/UP or -/DOWN button you may scroll between user presettable on time from 4 up to 60 seconds.



3.3.8 Setting audible attention signals on and off

With this option you can switch off the audible attention signals only (the audible alarms remain active). By pressing SEL/ESC button on this menu the on/off field at the bottom row starts flashing. By pressing the +/UP or -/DOWN button you may select between audible attention signals On or Off. You may confirm the selection by pressing SEL/ESC button again.



3.3.9 Deactivating the water contacts

⚠ WARNING

If you chose the option “Water contacts off”, Meridian will turn on with a delay of up to 1 minute into the dive. This will affect functioning of the dive computer.

Make sure the Meridian is on the surface mode before starting the dive.

By pressing SEL/ESC button on this menu the on/off field at the bottom row starts flashing. By pressing the +/UP or -/DOWN button you may switch between active or inactive water contacts. You may confirm the selection by pressing SEL/ESC button again.

👉 NOTE: With inactive water contact you prevent Meridian from switching to dive ready mode when your skin or surface moisture activates the water contact.



3.4 APNEA Settings

APNEA diving related selections are grouped in this menu.



By pressing the SEL/ESC button the following menu's can be accessed.

3.4.1 Setting the dual depth alarm

With this alarm you can set two independent depth alarms. By pressing the SEL/ESC button at this menu the first depth starts flashing. By pressing the +/UP or -/DOWN button you may select the first depth alarm from 5 to 100 meters (20..330 feet). By pressing SEL/ESC the first value is confirmed and the second alarm starts flashing. Like the first, by pressing the +/UP or -/DOWN button the second alarm may be set from 5 to 100 meters.

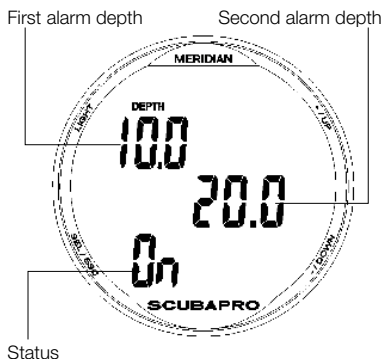

👉 NOTE: The first alarm is short sequence for attention and the second alarm is continuous. By setting the first alarm deeper than the second, it will

be masked by the continuous alarm and you cannot hear the first one.

3.4.2 Setting the depth incremental alarm

With this alarm you can set repetitive depth alarms at given depth increments. By pressing the SEL/ESC button in this menu the incremental alarm depth starts to flash. By pressing the +/UP or -/DOWN button you may select the alarm value from 5 to 100 meters (20..330 feet). By pressing SEL/ESC button the alarm value will be confirmed and the function at the bottom row starts flashing. By pressing the +/UP or -/DOWN button you may select the direction for the depth incremental alarm: off, dn (down), up or both.

Depth increment

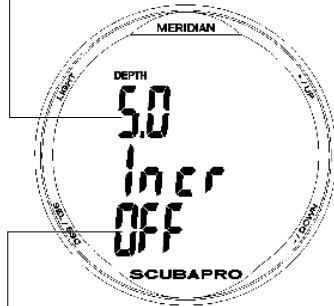

Status

3.4.3 Setting the dive time interval warning

You can set a time warning that repeats on given intervals. By pressing SEL/ESC button at this menu (SurF) the dive time interval time starts to flash. By pressing +/- you can select the interval from 15 seconds up to 10 minutes. By pressing SEL/ESC button the function starts to flash and you may select to enable or disable by choosing on/off with the +/UP and -/DOWN button. By pressing SEL/ESC again the selection will be confirmed.



Status

3.4.4 Setting the surface interval warning

You can set a time for recovery or start time for repetitive dive when training against given tables. By pressing SEL/ESC button at this menu the surface interval time starts to flash. By pressing +/- you can select the interval from 15 seconds up to 10 minutes. By pressing SEL/ESC button the function starts to flash and you may select to enable or disable by setting on/off with the +/UP or -/DOWN button. By pressing SEL/ESC again the selection will be confirmed.

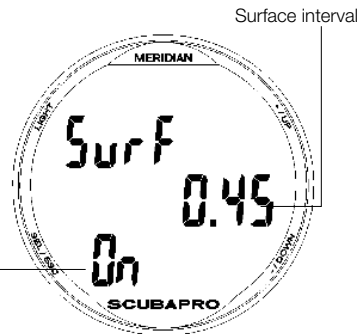

Status

3.4.5 Setting the low Heart Rate limit alarm

In APNEA diving a low heart rate is a key for low oxygen consumption and therefore for longer dives. However, an extremely low pulse at depth may lead to loss of awareness and is dangerous.

By pressing the SEL/ESC button at the PULSE menu the low heart rate value starts to flash. By pressing the +/UP or -/DOWN button you can set the value from 25 to 100 beats per minute. By pressing SEL/ESC button the value will be confirmed and function activation starts flashing. By pressing +/- you may select between on/off. By pressing SEL/ESC button the alarm will be confirmed.

Example: The HR alarm goes off if the heart rate reaches 40 or less beats per minute



3.4.6 Setting the Ascent speed alarm

With this alarm you can set ascent speed alarm. By pressing SEL/ESC at this menu (SPEED) the ascend speed starts to flash. By pressing the +/UP or -/DOWN button you may select the value from 0.1 to 5.0 meters/second (1..15 feet/second). By pressing SEL/ESC the value will be confirmed and the function starts flashing. By pressing +/- you may select if alarm will be active by setting on/off. By pressing SEL/ESC the selection will be confirmed.

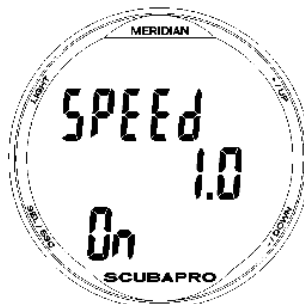

3.4.7 Setting the water density

At APNEA diving the exact depth is very important value. For the most accurate reading you must select the correct density of the water. Density depends on water temperature and salinity (salt content).

Some approximated densities at 20°C/68°F water:

- Average Ocean water has approximately 1025 gram/liter (59878 Grain/gallon).
- Mediterranean Sea has approximately 1027 gram/liter (59995 Grains/gallon).
- Red Sea has approximately 1029 gram/liter (60112 Grains/gallon).
- Black Sea has approximately 1012 gram/liter (59119 Grains/gallon).
- Baltic Sea has approximately 1004 gram/liter (58652 Grains/gallon).
- Fresh water (lake/quarry) has density approximately 1000 gram/liter (58417 Grains/gallon).

By pressing SEL/ESC at this menu (WATER) the water density value starts to flash. By pressing the +/UP or -/DOWN button you

may change the value between 1000 and 1050 gram/liter (58417..61339 Grains/gallon). By pressing the SEL/ESC button the value is confirmed.



Water density

3.5 Algorithm selection

You may select your Meridian operation mode between SCUBA, GAUGE and APNEA modes.

When Meridian has not been submerged for a while the display will appear as follows:



By pressing the SEL/ESC button at this menu the mode starts to flash. By pressing the +/UP or -/DOWN button you may select between SCUBA, GAUGE and APNEA modes. Pressing the SEL/ESC button will confirm the selection.

Since the GAUGE and APNEA modes are not tracking the tissue saturation, there is a 48h locking interval after the last dive in GAUGE or APNEA mode before change to a SCUBA mode is possible.

Meridian shown below has been dived in GAUGE mode and the NO CHANGE lock is still on for another 4 hours.



From the last SCUBA dive the change to GAUGE or to APNEA mode is possible only after the desaturation time has elapsed.

If you decide to change between modes before the 48h interval or full desaturation you must go to the desaturation reset menu and make a manual desaturation reset.

WARNING

Changing ALGO with remaining saturation could lead to injury or death.

3.6 Diving with Meridian

The functions of the buttons during diving are summarized in the table below.

Note that Meridian can be set to three dive modes: SCUBA, APNEA and GAUGE. Due to the operation differences also buttons have different functions in each mode.

LIGHT (Left upper button)	<ul style="list-style-type: none"> • Short press = backlight, • Long press = bookmark
+/UP (Right upper button)	<ul style="list-style-type: none"> • Short press = alternative display data • Short press in APNEA mode = switch between HR and ASC speed on display • Short press in GAUGE mode = alternative display data • Long press in GAUGE mode = reset average depth counter
-/DOWN (Right lower button)	<ul style="list-style-type: none"> • Short press = reset safety stop timer • Long press in APNEA mode = manual start and end the dive • Short press in GAUGE mode = start/stop timer
SEL/ESC (Left lower button)	<ul style="list-style-type: none"> • Long press = select manual gas switch • Short press (after long) = enter manual gas switch

3.6.1 Display information

Upon immersion, Meridian will automatically start to monitor the dive regardless of what state it was in prior to the immersion. Details on the information displayed can be found in the next sections.

The dive time is displayed in minutes. If during the dive you ascend to the surface, the time spent on the surface will only be counted if you descend again below 0.8m/3ft within 5 minutes. This allows for brief periods of orientation. While on the surface, the time will not show as progressing but it is running in the background. As soon as you submerge, the time will resume, including the time spent on the surface. If you spend more than 5 minutes at depth shallower than 0.8m/3ft, the dive will be considered ended, the logbook closed and a subsequent immersion would cause the dive time to start again from zero.

Maximum displayed time is 999 minutes. For dives longer than that, the dive time starts again from 0 minutes.

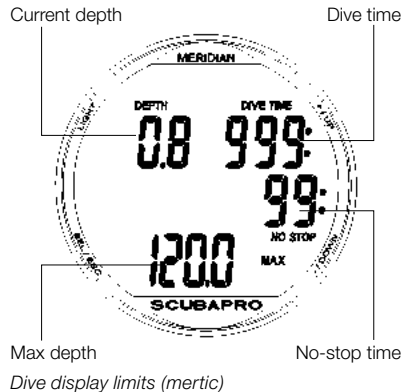

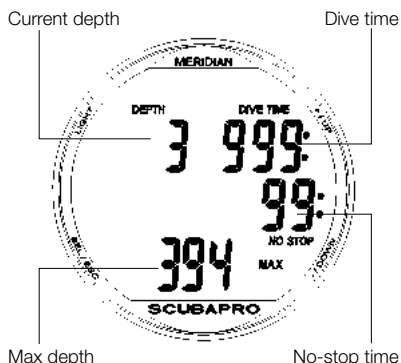

Dive display limits (imperial)

Depth: the depth is given in 10cm resolution when metric mode. When the depth is displayed in feet, the resolution is always 1 foot. At a depth shallower than 0.8m/3ft, the display shows --. Maximum possible depth is 120m/394ft.

No-stop time: calculated in real time and updated every 4 seconds. Maximum displayed no-stop times is 99 minutes.

⚠ WARNING

During all dives, perform a safety stop between 3 and 5 meters/10 and 15 feet for 3 to 5 minutes, even if no decompression stop is required.

Temperature: Meridian displays the water temperature during the dive and the air temperature on the surface. However, the skin temperature influences the measurement when worn at the wrist.

Decompression information: when Meridian calculates the need for a mandatory decompression stop, it shows you how long and how deep your deepest stop is. It also gives you the total ascent time. Stops deeper than 27m/90ft and total ascent times longer than 99 minutes are shown as "--".

Decompression information at MB L0: if you are diving with an MB level different than MB L0, you can ask Meridian to show you the decompression information pertinent to the underlying MB L0 calculation. For more

information on MB levels, please refer to chapter **3.11.15 Diving with MB levels**.

3.6.2 Display configuration during the dive

Throughout the dive, Meridian displays the current depth (upper left corner), the elapsed dive time (upper right corner) and the no-stop or decompression information (middle row).

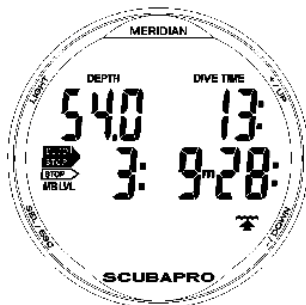

In addition, Meridian utilizes the lower row to display additional information regarding the dive. By **pressing** +/UP button will show, in sequence:

1. PDIS depth (when pending)
2. Maximum depth (only if 1m/3ft ascent detected)
2. Water temperature
3. Heart rate (if activated)
4. O₂ %
 - a. MOD of the active gas (if Gas d enabled)
 - b. If Gas 1 active then bail out info using only Gas 1 **at the middle row**
 - c. Active MB level
 - d. No-stop or decompression information at L0 (displayed in middle row, only if diving with an MB level other than L0)
5. CNS % if greater than 1%
6. Time of the day **in the middle row** (temperature at bottom row)

3.7 Altitude diving

3.7.1 Altitude classes, altitude warning and no-fly time after a dive

Going to altitude is in a way similar to starting an ascent from a dive: you expose your body to a lower partial pressure of nitrogen and consequently you start offgassing. After a dive, given the higher nitrogen loading in your body, even reaching an otherwise negligible altitude can potentially cause decompression sickness. Consequently, Meridian constantly monitors the ambient pressure and uses it to evaluate your nitrogen loading and offgassing. If Meridian notices a drop in ambient pressure not compatible with your current nitrogen loading, it will activate a warning to alert you of the potentially dangerous situation.

If you have remaining desaturation on Meridian, you can view the current altitude and the prohibited altitude by **pressing** the **-/DOWN** button from the main time display. In the top left corner, Meridian will display two numbers: the left number represents the current altitude, whereas the right number represents the prohibited altitude (the altitude which Meridian has computed to be incompatible with your current nitrogen saturation levels). Altitude here is given in classes from 0 up to 4. Please read chapter **3.7.2 Altitude and the decompression algorithm** for more details on this.

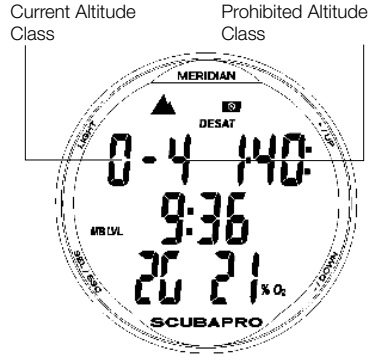

By pressing SEL/ESC button the next display will be shown:

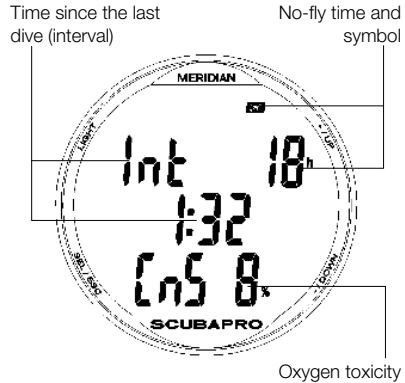

In the top right corner Meridian shows the **no-fly time** and the **NO FLY** symbol. The no-fly time is the time during which an exposure to the reduced pressure inside the cabin of an airplane could cause decompression sickness, as calculated by the decompression model in the dive computer.

In the top left Int is displayed (the time since the last dive) and in the middle row the time is counting.

In the bottom row the Oxygen toxicity (CNS O₂) is shown in % values.

After the full desaturation the interval display disappears and the Gas setting menu is shown directly.

⚠ WARNING

Flying while Meridian displays the NO FLY symbol can result in serious injury or death.

3.7.2 Altitude and the decompression algorithm

Atmospheric pressure is a function of altitude and of weather conditions. This is an important aspect to consider for diving, because the atmospheric pressure

surrounding you has an influence on ongassing and offgassing of nitrogen. Above a certain altitude, the decompression algorithm has to change in order to account for the effect of the change in atmospheric pressure.

Meridian divides the possible altitude range in 5 classes that are illustrated in the illustration below:



Elevation	Altitude Class	Barometric switch point	Dive Computer mode
4000 m 13120 ft	C4	610 mbar 8.85 psi	GAUGE (no deco data)
3000 m 9840 ft	C3	725 mbar 10.51 psi	SCUBA
2000 m 6560 ft	C2	815 mbar 11.82 psi	SCUBA
1000 m 3280 ft	C1	905 mbar 13.13 psi	SCUBA
0 m 0 ft	C0		SCUBA

The Altitude Classes are defined in terms of approximate elevations because the effect of weather conditions can make the pressure switch point occur at different levels.

⚠ WARNING

At Altitude Class 4, Meridian functions in GAUGE mode only (automatic switch from dive computer mode).

👉 **NOTE:** You can check your current Altitude Class and elevation by activating the altitude meter. Refer to chapter **Checking the Altitude** on how to do so.

👉 **NOTE:** Meridian monitors the altitude automatically: it monitors the atmospheric pressure every 60 seconds and if a sufficient drop in pressure is detected, the following will occur it does the following:

- A new Altitude Class will be indicated

and if applicable, the prohibited Altitude Class too;

- *The desaturation time will be indicated, which in this case is an adaptation to the new ambient pressure. If a dive is started during this adaptation time, Meridian considers it a repetitive dive, since the body has residual nitrogen.*

3.7.3 Prohibited altitude

Increasing altitude, as well as flying after diving, exposes your body to a reduced ambient pressure. In a way similar to the no-fly time, Meridian advises you as to which Altitude Classes are safe after a dive and which are not. For example, if you must drive over a mountain pass to return home after a dive, it can be quite important to have this information.

Current Altitude Class

Ascent to Altitude Class 4 prohibited

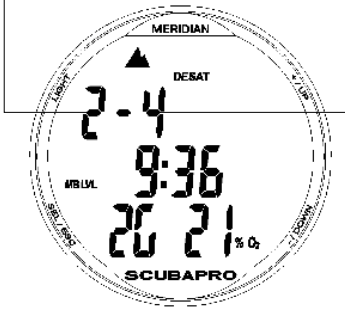

In the example above, the diver is presently at Altitude Class 2 and should not reach altitudes of class 4 (prohibited Altitude Class).

Meridian has an audible altitude warning: if you were to reach an altitude, that according to Meridian, is incompatible with your current residual nitrogen levels, it will warn you with an altitude warning.

3.7.4 Decompression dives in mountain lakes

In order to assure optimal decompression even at higher altitudes, the 3m/10ft decompression stage is divided into a 4m/13ft stage and a 2m/7ft stage in Altitude Class 1, 2 and 3.

If atmospheric pressure is below 610mbar (altitude higher than 4000m/13300ft), no decompression calculation is carried out by Meridian (automatic GAUGE mode). In addition, the dive planner is not available in this altitude class.

3.8 No-dive warning after a dive

If Meridian detects a situation of increased risk (due to the potential microbubble accumulation from previous dives or a CNS O₂ level above 40%), the **NO DIVE** symbol will appear on the display to advise you against performing another immediate dive right away. The suggested time interval that you should wait prior to diving is shown on the dive mode display.



WARNING

If the “no-dive” warning is visible during the surface interval, the diver should not undertake another dive.

If the warning is prompted by microbubble accumulation (as opposed to CNS O₂ over 40%) and you dive anyway, you will have shorter no-stop times or longer decompression times. Moreover, the duration of the microbubble warning at the end of the dive can increase considerably.

3.9 SOS

If you stay above a depth of 0.8m/3ft for more than 3 minutes without observing a prescribed decompression stop, Meridian will switch into **SOS** mode. Once in **SOS** mode Meridian will lock up and will be inoperable as a dive computer for 24 hours. If it is used for diving within the 24 hours of an **SOS** lock, it will automatically switch to GAUGE mode and provide no decompression information.

⚠ WARNING

- Violating a mandatory decompression obligation may result in serious injury or death.
- Serious injury or death may result if a diver does not seek immediate treatment should any signs or symptoms of decompression sickness occur after a dive.
- Do not dive to treat symptoms of decompression sickness.
- Do not dive when the dive computer is in SOS mode.

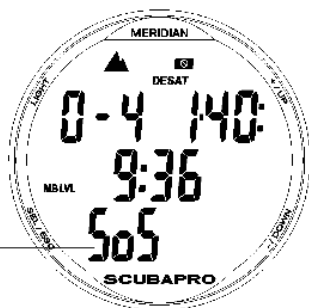

SOS

The display shows the same information as in presence of desaturation, but at the lowest row SOS is displayed.

3.9.1 Desaturation reset

Meridian allows you to reset the desaturation in the dive computer. Any tissue saturation information from a recent dive will be reset to zero and the dive computer treats the next dive as a non-repetitive dive. This is useful when the dive computer is loaned to

another diver who has not dived in the last 48 hours.

☞ *NOTE: After a desaturation reset the change between the modes: GAUGE, APNEA and SCUBA are possible immediately. However, since the GAUGE and APNEA modes are not tracking your tissue nitrogen loading, it is recommended to keep the initial intervals between changes on modes.*

⚠ WARNING

Diving after having reset the desaturation is extremely dangerous and is very likely to cause serious injury or death. Do not reset the desaturation unless you have a valid reason to do so.

☞ *NOTE: Removing and replacing the battery will not reset the desaturation. Meridian stores tissue saturation information in non-volatile memory. For the time during which the dive computer is without battery, the desaturation calculation is frozen and resumes from where it had left off as soon as a new battery is installed.*

3.10 Diving with nitrox or with another decompression gas

Nitrox is the term used to describe breathing gases made of oxygen-nitrogen mixes with oxygen percentage higher than 21% (air). Because Nitrox contains less nitrogen than air, there is less nitrogen loading on the diver's body at the same depth as compared to breathing air.

However, the increase in oxygen concentration in Nitrox implies an increase in oxygen partial pressure in the breathing mix at the same depth. At higher than atmospheric partial pressures, oxygen can have toxic effects on the human body. These can be lumped into two categories: Sudden effects due to oxygen partial pressure over 1.4bar. These are not related to the length of the exposure to high partial

pressure oxygen, and can vary in terms of the exact level of partial pressure they happen at. It is commonly accepted that partial pressures up to 1.4 bar are tolerable, and several training agencies advocate maximum oxygen partial pressures up to 1.6 bar.

Long exposure effects to oxygen partial pressures over 0.5 bar due to repeated and/or long dives. These can affect the central nervous system, cause damage to lungs or to other vital organs. Long exposures can be divided to more severe Central Nervous System effects and less dangerous long term Pulmonary Toxicity effects.

Meridian treats high ppO_2 and long exposure effects in the following ways:

Against sudden effects: Meridian has an MOD alarm set for a user-defined ppO_2max . As you enter the oxygen concentration for the dive, Meridian shows you the corresponding MOD for the defined ppO_2max . The default value of ppO_2max from the factory is 1.4bar. This can be adjusted to your preference between 1.0 and 1.6bar. It can also be turned OFF. Please refer to chapter **3.2 Gas settings** for more information on how to change this setting.

Against long exposure effects: Meridian “tracks” the exposure by means of the CNS O_2 clock. At levels of 100% and higher there is risk of long exposure effects, and consequently Meridian will activate an alarm when this level of CNS O_2 is reached. Meridian can also warn you when the CNS O_2 level reaches 75% (see section CNS alarm). Note that the CNS O_2 clock is independent of the value of ppO_2max set by the user.

The CNS O_2 clock increases when the oxygen partial pressure is higher than 0.5bar, and decreases when the oxygen partial pressure is lower than 0.5bar. Hence, while on the surface breathing air you will always be decreasing the CNS O_2 clock. During the dive, the depth at which 0.5bar is reached for various mixes is as follows:

Air:	13m/43ft
32%:	6m/20ft
36%:	4m/13ft

 **NOTE:**

- the O_2 concentration of Gas d can only be set to a value higher than the O_2 concentration for Gas 1.
- O_2 concentration setting shown “-” means that gas is disabled.
- Meridian requires that the MODs of Gas 1 and Gas d be at least 3m/10ft apart.
- Setting the ppO_2max value to OFF applies to Gas 1 only. Gas d is always limited to a maximum value of ppO_2max of 1.6bar.
- For oxygen concentrations of 80% and higher, the ppO_2max is fixed at 1.6 bar and cannot be changed.
- The MOD for Gas d is the switch depth for that gas. This is what Meridian uses for its calculation, warnings and suggested switch point.
- When diving with more than one gas mixture, the Nitrox reset time function (described in section 2.3.5) has the following effect:
 - Gas 1 is set to 21%
 - Gas d is set to OFF.

3.10.1 Diving with two gas mixtures

Meridian is equipped with the ZH-L8 ADT MB PMG algorithm. PMG stands for Predictive Multi Gas, meaning that when you program more than one gas mixture, Meridian will predict the switch to the higher oxygen concentration gas at the depth that you specified and alert you at all times with a decompression schedule comprehensive of both gas mixtures that you programmed. In other words, you get full credit at any point during the dive for all the extra gas that you are carrying with you. At the same time Meridian can also show you what the decompression schedule would be if you were to finish the dive using only the gas mixture that you are currently breathing from, so that you can be prepared in the event that

something did not work as planned.

⚠ WARNING

- Diving with two gas mixtures represents a much higher risk than diving with a single gas mixture, and mistakes by the diver may lead to serious injury or death.
- During dives with two gas mixtures, always make sure you are breathing from the tank that you intend to breathe from. Breathing from a high oxygen concentration mix at the wrong depth can kill you.
- Mark all your regulators and tanks so that you cannot confuse them under any circumstance.
- Before each dive and after changing a tank, ensure that each gas mixture is set to the correct value for the corresponding tank.
- Get a proper training and certifications to make multi-gas dives prior of making them.

Meridian enables you to use up to two gas mixtures during the dive (air and Nitrox only). The two mixtures are labeled 1 and d, and must be in ascending order of the oxygen fraction.

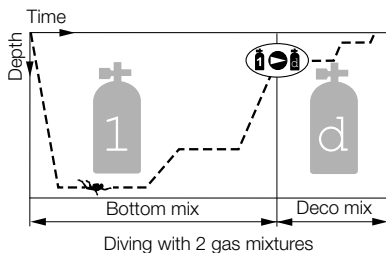

Switching gas mixture during the dive

During the ascent phase, when you reach a depth corresponding to the MOD of **Gas d**, Meridian will suggest that you perform the switch. An audible sequence goes off, and the text **Gas d** starts flashing on the display together with the value of the MOD. You have 30 seconds to respond to this message, otherwise Meridian will consider that Gas d will not be used and adapts the decompression schedule accordingly. To confirm the gas switch, **press SEL/ESC button**.

👉 *NOTE: Start breathing from the tank with the new gas mixture before confirming a switch.*

⚠ WARNING

Always make sure you are switching to the intended gas. Failure to do so may result in serious injury or death.

After you confirm the switch, the text **Gas d** remains on the screen for five seconds without flashing.

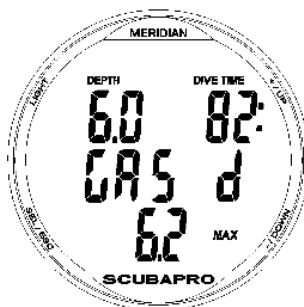

Switching back to a gas mixture with lower oxygen concentration

There may be situations in which you have to switch back to Gas 1 from Gas d. This can happen for instance if you want to descend again below the MOD for Gas d, or if for instance you have run out of Gas d during the decompression. At this point you can manually initiate the gas switch by **pressing and holding SEL/ESC button**. Meridian will display the text **Gas 1** and its MOD, flashing. At this point **press SEL/ESC button** to confirm the switch. Meridian will display the text **Gas 1** for five seconds without flashing and adapt the decompression schedule accordingly.

Gas switch not carried out at the planned depth

If you fail to confirm the change to Gas d within the 30 seconds of when Meridian suggested it, Gas d is excluded from the decompression calculation and the decompression schedule is adapted

accordingly, basically reflecting the fact that you will finish the dive using Gas **1** only.

NOTE: if after Meridian has changed the decompression schedule to reflect the missed gas switch, you descend again below the MOD for Gas **d**, Meridian reintroduces Gas **d** into the calculations and the decompression schedule changes accordingly.

Delayed gas switch

You can catch up on a planned gas mixture switch at any time by selecting the gas manually. **Press and hold** SEL/ESC button to start the gas switch procedure. Meridian will show the text **Gas d** and its MOD flashing on the display. This helps you verify that you are performing a switch to a safe gas. At this point **press SEL/ESC button** to confirm the switch. Meridian will display the text **Gas d** without flashing and adapt the decompression schedule accordingly.

Submerging below the MOD after a gas switch

If after having switched to Gas **d** you inadvertently drop again below the MOD for that mixture, the MOD alarm will immediately go off. Either switch back to Gas **1**, or ascend above the MOD for Gas **d**.

3.11 Warnings and alarms

Meridian can alert you of potentially dangerous situations via warnings and alarms. **You can only modify the warning and alarm settings via PC interface.**

Warnings represent situations that require the diver's attention, but ignoring them does not represent an immediate risk. It is up to you to decide which ones you would like to be active and which ones not. The available warnings are:

3.11.1 CNS O₂ = 75%

Meridian tracks your oxygen uptake via the CNS O₂ clock. If the calculated value of CNS O₂ reaches 75%, Meridian will emit a sequence of audible beeps for 12 seconds

and the value of the CNS O₂ will be flashing in the lower right corner. The flashing will continue until the value of CNS O₂ drops under 75%.

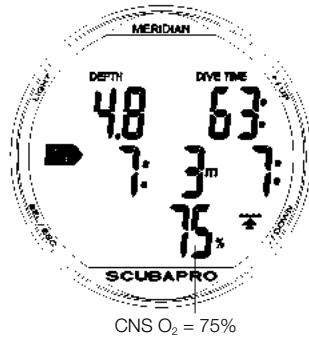

CNS O₂ = 75%

3.11.2 No-Stop time = 2 minutes

If you wish to avoid unintentionally performing a decompression dive, Meridian can activate a warning when the no-stop time reaches 2 minutes. This applies to both L0 no-stop and MB no-stop time (see chapter 3.11.15 Diving with MB levels for more information on MB level diving). It gives you the opportunity to start ascending before incurring a decompression stop or a level stop obligation.

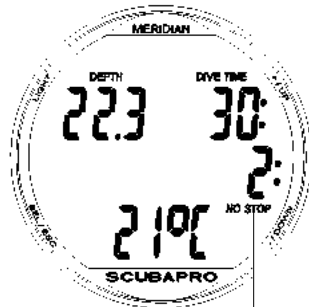

No-Stop time = 2 minutes

Meridian emits a sequence of audible beeps for 12 seconds and the no-stop time will flash. The flashing will continue until you ascend sufficiently for the no-stop time to grow to 3 minutes, or until Meridian enters into decompression.

3.11.3 Entering decompression

Meridian can activate a warning when the first mandatory decompression stop appears. This alerts the diver to the fact that a direct ascent to the surface is no longer possible. This warning applies to dives with the dive computer set to L0 only.

Meridian emits a sequence of audible beeps and the DECO STOP symbol flashes, both for 12 seconds, when the no-stop time ends and a mandatory (L0) stop is required before reaching the surface.

3.11.4 Entering level stops

When diving with a microbubble (MB) level different than L0, Meridian can warn you when you are no longer in the MB no-stop phase. See section **3.11.15 Diving with MB levels** for more information on MB level diving.

Meridian emits a sequence of audible beeps and the STOP symbol flashes, both for 12 seconds, when the MB no-stop time ends and a level stop is required before you ascend to the surface.

3.11.5 L0 no stop time = 2 minutes when diving an MB level

When diving with an MB level higher than L0, the underlying L0 information is not directly visible on the display (though it is accessible as alternate information). You can choose to have Meridian warn you when the underlying L0 no-stop time reaches 2 minutes while diving with an active MB level higher than L0.

Meridian emits a sequence of audible beeps and the MB LVL symbol flashes, both for 12 seconds, when the L0 no-stop time reaches 2 minutes while diving with an active MB level higher than L0.

3.11.6 Entering deco when diving an MB level

When diving with an MB level higher than L0, the underlying L0 information is not directly visible on the display (though it is accessible as alternate information).

You can choose to have Meridian warn you when you are about to enter a decompression obligation while diving with an active MB level higher than L0.

Meridian emits a sequence of audible beeps and the **DECO STOP** symbol flashes, both for 12 seconds, when the L0 no-stop time ends while diving with an active MB level higher than L0.

Alarms can not be turned off because they represent situations that do require immediate action by the diver. There are five different alarms:

WARNING

- When in GAUGE mode, all warnings and all alarms are OFF aside for the low battery alarm.
- When Meridian is set to SOUND OFF mode, all audible alarms and warnings are switched off.

3.11.7 Ascent rate

As you ascend during a dive, the pressure surrounding you diminishes. If you ascend too quickly, the ensuing pressure reduction could lead to microbubble formation. If you ascend too slowly, the continued exposure to high ambient pressure means that you will continue loading some or all of your tissues with nitrogen. Consequently, there is an ideal ascent rate that is slow enough to minimize microbubble formation yet fast enough to minimize the effect of continued loading on your tissues.

The pressure reduction that the body can tolerate without significant microbubble formation is higher at depth than it is in the shallows: The key factor is not the pressure drop by itself, but rather the ratio of the pressure drop relative to the ambient pressure. This means that the ideal ascent rate at depth is higher than it is in the shallows.

Along these lines, Meridian employs a variable ideal ascent rate: its value ranges between 7..20m/min / 23..66ft/min and the actual breakdown by depth range is listed in the chart below.

DEPTH		ASC SPEED	
m	ft	m/min	ft/min
0	0	7	23
6	20	8	26
12	40	9	29
18	60	10	33
23	75	11	36
27	88	13	43
31	101	15	49
35	115	17	56
39	128	18	59
44	144	19	62
50	164	20	66

If the ascent rate is greater than 110% of the ideal value the **SLOW** symbol appears. For ascent rates higher than 140%, the **SLOW** symbol starts to flash.

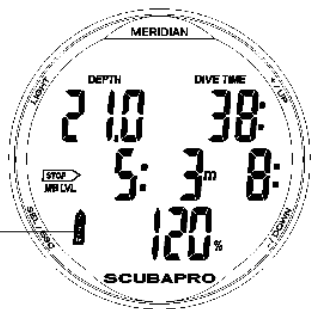

Slow symbol

Meridian also provides an audible alarm in case of ascent rates exceeding 110%: the intensity of the alarm increases in direct proportion to the degree that the ideal ascent rate is exceeded.

In case of a fast ascent, Meridian may require a decompression stop even within the no-stop phase because of the danger of microbubble formation.

From great depth a slow ascent may cause heightened saturation of tissues and an extension of both decompression duration and total ascent time. At shallow depth, a slow ascent may shorten the decompression duration.

Excessive ascent rates for longer periods are entered in the logbook.

WARNING

The ideal ascent rate must not be exceeded at any time since this could lead to microbubbles in the arterial circulation which could cause serious injury or death.

The alarm persists for as long as the ascent rate is 110% or more of the ideal ascent rate.

3.11.8 MOD/ppO₂

WARNING

- The MOD should not be exceeded. Disregarding the alarm can lead to oxygen poisoning.
- Exceeding a ppO₂ of 1.6bar can lead to sudden convulsions resulting in serious injury or death.

If you exceed the MOD, the depth will start to flash and in the bottom row the MOD is displayed so you can see by how much you have exceeded it. In addition, Meridian will beep incessantly. Both the flashing of the depth value and the beeping will continue for as long as you stay deeper than the MOD.

3.11.9 CNS O₂ = 100%

WARNING

When the CNS O₂ reaches 100% there is danger of oxygen toxicity. Start procedure to terminate the dive.

Meridian tracks your oxygen uptake via the CNS O₂ clock. If the calculated value of

CNS O₂ reaches 100%, Meridian will emit a sequence of audible beeps for 12 seconds and the value of the CNS O₂ will be flashing in the lower right corner. The flashing will continue until the value of CNS O₂ drops under 100%.

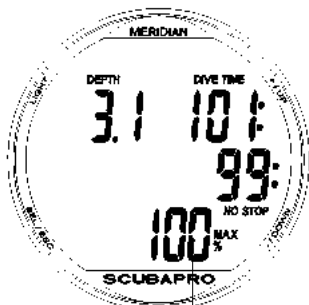

CNS O₂ = 100%

The audible signal is repeated for 5 seconds in one minute intervals after the first occurrence and for as long as the value of CNS O₂ stays at or above 100% or until the ppO₂ drops under 0.5bar (see chapter 3.10 Diving with nitrox or with another decompression gas for a list of depths at which ppO₂ equals 0.5bar for some typical Nitrox mixes).

3.11.10 Missed decompression stop

⚠ WARNING

Violating a mandatory decompression obligation may result in serious injury or death.

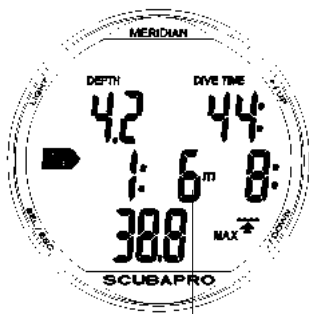

Omitted deco stop

If in presence of a required decompression stop you ascend more than 0.5m/2ft above

the required stop, Meridian will trigger an alarm: the value of the current depth and the value of the required stop depth will flash, and a sequence of beeps can be heard. This will continue for as long as you stay 0.5m/2ft or more above the required stop.

3.11.11 Low battery

⚠ WARNING

Do not start a dive if the battery symbol is displayed flashing on the screen on the surface. The dive computer may fail to function during the dive and this could lead to serious injury or death.

During the dive, Meridian alerts you of precarious battery situations in two ways:

By displaying a steady battery symbol on the screen. This means you can finish the dive but you should replace the battery once you return to the surface;

By displaying a flashing battery symbol on the screen. This means you need to start the procedure to terminate the dive, as there is not enough energy in the battery to ensure proper continued functioning and the dive computer may fail. If the battery symbol is flashing, the backlight cannot be activated and the audible warnings and alarms are not available anymore.

3.11.12 Setting bookmarks

By **press and hold** LIGHT button you can set any number of bookmarks as reminders of particular moments during the dive. The bookmarks will appear on the dive profile in JavaTRAK.

3.11.13 Safety stop timer

If a minimum depth of 10m/30ft has been reached during the dive, at a depth of 5m/15ft the safety stop timer will automatically start a countdown. If you go below 6.5m/20ft, the timer will disappear and the no-stop time is shown again. Upon returning to 5m/15ft, the timer will start again automatically. As long as you are

shallower than 6.5m/20ft and there are no decompression obligations, you can **press** –/DOWN button to restart the countdown manually.

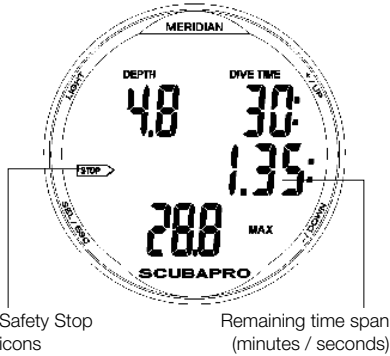

3.11.14 Activating the backlight

To activate the backlight, **press LIGHT**. The default duration of the backlight is 6 seconds, but you can set it between 4 and **60 seconds** in one second increments.

The backlight is not available when the **BATTERY CHANGE** warning appears.

3.11.15 Diving with MB levels

Microbubbles are tiny bubbles that can build up inside a diver's body during any dive and normally dissipate naturally during an ascent and on the surface after

a dive. Dives within no-stop time and observance of decompression stops do not prevent the formation of microbubbles in the venous blood circulation. Meridian has been equipped with an enhanced SCUBAPRO algorithm, named ZH-L8 ADT MB, to reduce the formation of these microbubbles.

This enhanced algorithm allows the user to choose a level of conservatism over and in addition to the worldwide proven safety record of the standard ZH-L8 ADT algorithm. There are five levels of added conservatism (or MB levels), from L1 to L5, with L5 being the most conservative and L1 being just a bit more conservative than the standard ZH-L8 ADT, here referred to as L0.

Choosing an MB level between L1 and L5 makes the algorithm more conservative, therefore the diver will have either shorter no-stop times or deeper and longer decompression stops (referred to as level stops) than when diving with L0. Consequently the body will either take up less nitrogen (shorter no-stop dives) or will be able to off-gas more before returning to the surface (dives with level stops). Both work towards reducing the amount of microbubbles present in the body at the end of the dive.

Please refer to chapter **3.3.3 Setting the Micro Bubble level** for information on setting the MB level.

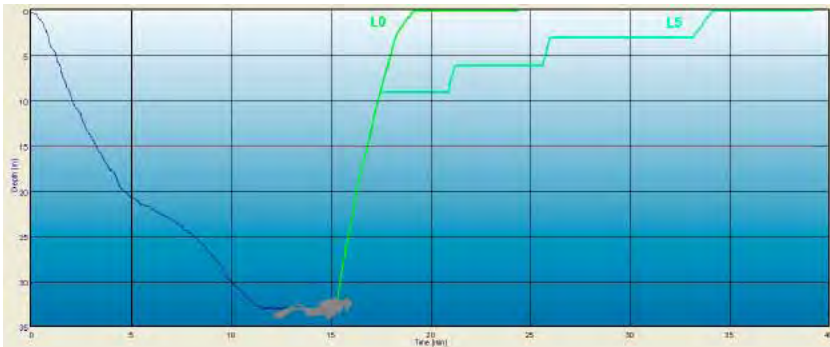

3.11.16 Display information

When diving with an MB level other than L0, Meridian still carries out all calculations relating to L0 in the background. To understand the relation between set MB level and the underlying L0 calculation and

how the information appears on the display, we shall use the example of a dive with MB L3 set in the dive computer.

L3 information on display	L0 information in background	Display details
No-stop	No-stop	Display shows L3 no-stop time.
Level stop	No-stop	Display shows L3 level stop information. The white STOP symbol appears on the display.
Level stop	Decompression	Display shows L3 level stop information. In addition to the white STOP symbol, also the black DECO symbol appears to indicate that also L0 is in decompression.

3.11.17 Display of underlying L0 decompression information

During the dive, the information displayed is always relative to the active MB level. However, the underlying L0 data is available as one of the alternate information fields. When **pressing** the **+/UP** button the appropriate number of times, the L0 information will be visible instead of the active MB level information for 5 seconds, after which it is replaced again by the information relative to the active MB level. While the L0 information is shown, the symbol **L0** appears in the lowest row of the display. This allows you to be aware of what the maximum possible no-stop time is or what the mandatory decompression requirements are.

3.11.18 Cascading MB levels

When diving with an MB level, Meridian carries out all calculations relating to L0 and to all MB levels in between the currently active one and L0. This gives the diver the flexibility to start with a given MB level but to cascade down to a less conservative level during the dive: if you start the dive at L4 but decide not to carry out all the required L4 stops, you can cascade down through L3, L2, L1 all the way to L0. Only decompression stops relating to L0 are mandatory and must be respected at all times, whereas the level stops calculated by the MB levels are recommended but not mandatory.

3.11.19 Level stop ignored/MB level reduced

If a level stop is required and you ascend 1.5m/5ft or more above it, Meridian will reduce your active MB level to the next one compatible with the current depth. When this happens, the new active MB level is permanently displayed on the screen. It is no longer possible to finish the dive with the MB level set at the beginning of the dive. When the level stop depth is the same as the deco stop depth, ascending 1.5m/5ft above it will cause Meridian to cascade down to L0.

At the end of the dive, for five minutes after reaching the surface, the active (reduced)

MB level is shown on the display. After five minutes Meridian changes to surface mode and switches back to the MB level set prior to the dive.

3.11.20 PDI Stops

Meridian is equipped with the innovative Profile Dependent Intermediate Stops introduced on other SCUBAPRO dive computers.

PDI Stop optimizes the leading compartment off gassing with a low gradient at depth which is calculated from the current profile.

After the dive profile has reached a level where PDI Stop is recommended the Meridian shows symbol PDIS and the depth of the suggested Stop at the bottom row.

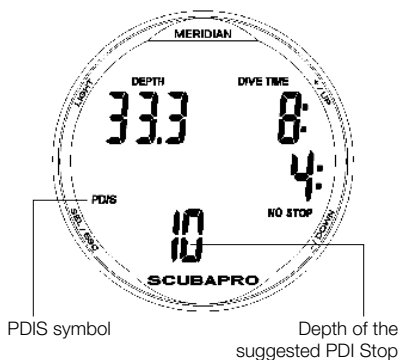

When ascending to a PDI stop depth and there is no decompression obligation, a stop sign, 2 minute down counter and flashing PDIS symbol are shown at the middle row.

Once PDIS depth has been reached, you should stay on the zone that is -0.5m..+3.0m / -2ft..+10ft from the shown PDIS depth. If you descend below this zone the PDIS counter will be deactivated and Meridian calculates a new PDIS depth.

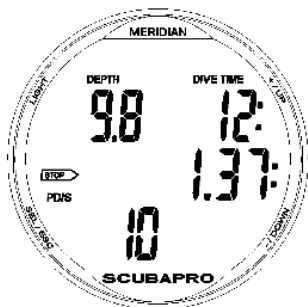

If decompression is already required this information remains in the middle row. In that case the PDIS counter is not shown but only the PDIS symbol is flashing for the 2 minutes that are recommended to remain in the PDIS zone.

⚠ WARNING

Even when performing a PDI stop, you still **MUST** perform a safety stop at 5m/15ft for 3 to 5 minutes. Performing a 3 to 5 minute stop at 5m/15ft at the end of any dive is still the best thing you can do for yourself!

3.12 GAUGE mode

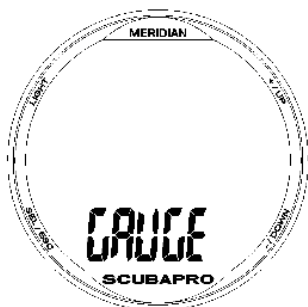

When Meridian is set to GAUGE mode, it will only monitor depth, time, and temperature, and will not carry out any decompression calculations. You can only switch to GAUGE mode if the dive computer is completely desaturated. All audible and visual warnings and alarms, other than the low battery alarm, are turned off.

⚠ WARNING

Dives in GAUGE mode are performed at your own risk. After a dive in GAUGE mode you must wait at least 48 hours before diving using a decompression dive computer.

When on the surface in GAUGE mode, Meridian will show neither the remaining desaturation time nor the CNS O₂% value. It will however display a surface interval up to 24 hours and a 48 hour no-fly time. This no-fly time is also the time during which you cannot switch back to dive computer mode.

The GAUGE mode surface display after a dive shows the dive time at the top row. In the middle row the stopwatch is running from the dive start or last manual restart. On the bottom row the maximum depth of the dive is shown. After 5 minutes timeout the display changes to GAUGE menu mode.

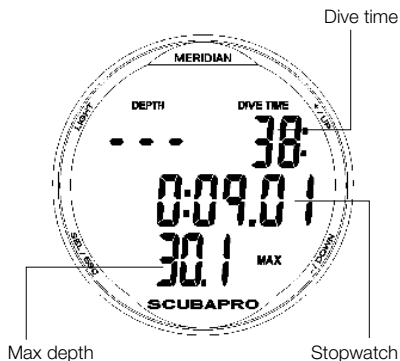

During a dive in GAUGE mode, Meridian displays a stopwatch in the middle row. This can be reset and restarted by **pressing +/UP button**.

While in GAUGE mode, the average depth can be reset. To reset the average depth, **press and hold -/DOWN button**

Similarly to the regular dive computer mode, **press and hold** button +/UP to view the time of day for 5 seconds in the middle row and other alternative information at the bottom row. In the display below the time of the day has been selected and it is

3. Meridian as a dive computer

1 second past 10 o'clock combined with water temperature that is 20°C.

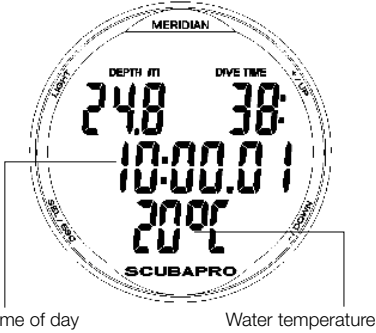

Alternative information can be selected in the following order:

1. Max depth (after 1m/3feet ascent detected)
2. Temperature
3. Average depth
4. Current time of the clock **at the middle row**, temperature on the bottom row

3.13 APNEA mode



Meridian has an advanced APNEA diving mode. The main features include faster sampling rate than in normal SCUBA mode and alarm functions tailored to APNEA diving.

Meridian measures the depth in APNEA mode every 0.25 seconds to ensure the precise maximum depth. In logbook the data is saved in 1 second intervals. The higher amount of saved data requires more space and the consequence is that approx 10 hours of log data can be stored in APNEA mode.

In APNEA mode it is also possible to start and stop the dive manually by pressing the -/DOWN button. This way you can use the meridian for static APNEA dives, where normal dive start depth of 0.8 meters will not start a new dive.

As with GAUGE mode, Meridian doesn't carry out any decompression calculation. You can only switch to APNEA mode if the dive computer is completely desaturated.

APNEA mode at surface after a dive shows the maximum depth and the dive duration (4 minutes 47 seconds in the example below) at top row. In the middle row the surface interval counter is counts 15 minutes and if no repetitive dive is done the Meridian turns to APNEA menu display. On the bottom row the sequential number of APNEA dives on this session is shown.

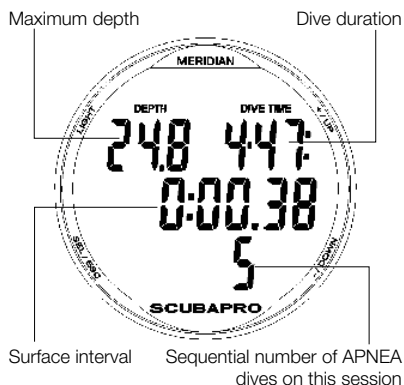

APNEA mode at surface

APNEA mode during the dive shows at top row the current depth, at middle row the time and at bottom row the sequential number of the dive at this session. When diver is ascending or descending the speed is automatically shown at bottom row.

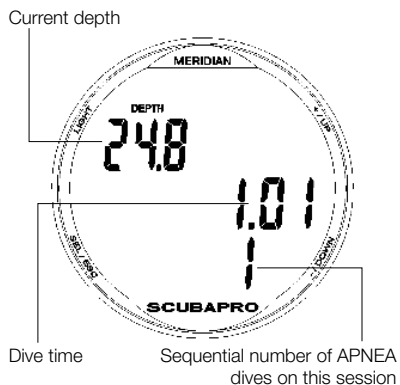

APNEA mode during the dive

Alternative information can be selected by pressing +/UP button. The information can be scrolled in following order:

1. Sequential dive number
2. Heart rate (if activated)

4. MERIDIAN ACCESSORIES

4.1 HR belt

Meridian receives the signal of the SCUBAPRO heart rate belt. The position to wear a HR belt is shown below.

Adjust the strap so that it is comfortable to wear but so that it holds on the place.

When using a diving suit the HR belt must be directly against the skin.

Moisten the electrode areas if your skin is dry or when using a dry suit.

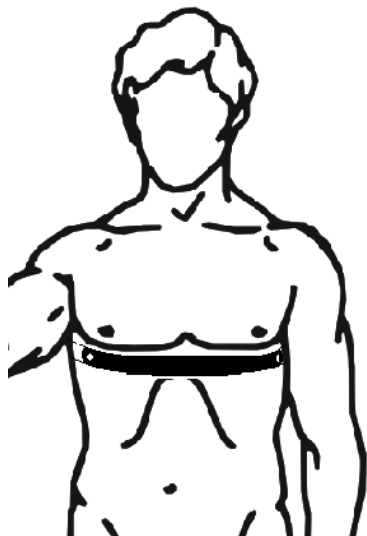

You must enable the heart rate setting at your Meridian, refer to chapter **3.2.4 Workload settings (pulse limits)** of how to do this.

After a dive rinse the heart rate belt in fresh water, dry it and store on a dry place.

With completely sealed HR belts the battery cannot be changed.

We recommend having the battery change by authorized SCUBAPRO dealer for the HR belts with a battery cap.

Check the operation conditions and depth rating of the HR belt from the unit or its package.

4.2 Nylon arm strap

Divers using thick neoprene wetsuit or drysuit may prefer longer arm strap. Meridian can be equipped with one piece 31cm/12inch Scubapro nylon arm strap.



NOTE: The Meridian arm strap is attached with Solid Stainless Steel pins that are splintered on one end. Always push the pins out with the splintered end first. In the housing the splintered side can be recognized from slightly larger diameter guiding at the hole. The disassembly and assembly of the arm strap requires a special tool. We recommend the arm strap change to be done by authorized SCUBAPRO dealer.



5. MERIDIAN PC INTERFACE

5.1 Cradle

The communication between Meridian and PC/MAC is possible only with a cradle.



The communication between the Meridian and the cradle is established via the contact on the case. Therefore if the water contact or the spring contact of the cradle has dirt on the surface, this should be cleaned with a piece of clothing before use.

To avoid scratching your Meridian, first place contacts together and then click the Meridian to the cradle.

5.2 Introduction to SCUBAPRO LogTRAK

LogTRAK is the software that allows Meridian to communicate with a Windows-based PC or Mac OS.

In order to take advantage of any of these features, you need to establish a communication between your PC and Meridian with a cradle.

To start the communication

1. Connect the cradle to your PC;
2. Launch SCUBAPRO LogTRAK on your PC
3. Select the serial port where the cradle is connected
Extras -> Options -> download



Select the COM port that is used for Meridian cradle.

4. Place the Meridian on the cradle



5.2.1 Download dive profiles

From LogTrak, by selecting Dive -> Cradle: Download Dives you can transfer the Meridian Logbook to your PC or MAC.

There are three main views each showing a specific part of your dive logs:

- Profile showing the graphical data of the dive.
- Details about the dive, where you can edit for example the equipment and tank information.
- Location, which shows your dive site at the world map.

The selection tabs for views are on the top of the main window.



Read chapter **3.11 Warnings and alarms** about the possible selections that you can modify on your Meridian.

You may also change the shown units between metric/imperial. Select Extras -> Options -> measurement units:

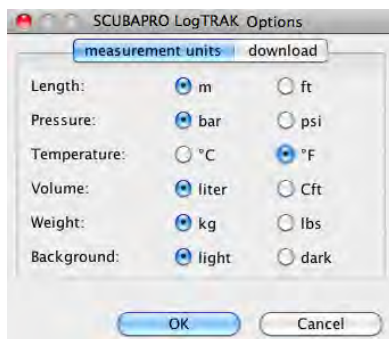

5.2.2 Change warnings/settings of the Meridian and reading dive computer info

By selecting Extras -> Computer settings you can enable/disable warnings that cannot be changed at Meridian via dive computer info.

6. TAKING CARE OF MERIDIAN

6.1 *Technical information*

Operating altitude:

with decompression – sea level to approximately 4000m/13300ft
without decompression (GAUGE mode) – at any altitude

Max operating depth:

120m/394ft; resolution is 0.1m until 99.9m and 1m at depth deeper than 100m. Resolution in ft is always 1ft. Accuracy is within 2% $\pm 0.2\text{m}/1\text{ft}$.

Decompression calculation range:

0.8m to 120m / 3ft to 394ft

Clock:

quartz clock, time, date, dive time display up to 999 minutes

Oxygen concentration:

adjustable between 21% and 100%

Operating temperature:

-10°C to +50°C / 14F to 122F

Power supply:

CR2032 lithium battery

Life of the battery:

2 years or 300 dives, whichever ever comes first. Actual battery life depends on the number of dives per year, the length of each dive, the water temperature and the usage of backlight.

6.2 *Maintenance*

The depth accuracy should be verified every two years, by an authorized SCUBAPRO dealer. Aside from that, Meridian is virtually maintenance free. Meridian is manufactured from highest grades of stainless steel. Salt water and substances dissolved in it may cause corrosion, surface rust or build an organic film which may disturb the functions of the Meridian. Therefore, it is necessary to rinse it carefully with fresh water after each dive and change the battery when needed. To avoid possible problems with your Meridian, the following recommendations will help assure years of trouble free service:

- avoid dropping or jarring your Meridian
- do not expose Meridian to intense, direct sunlight
- do not store Meridian in a sealed container, always ensure free ventilation
- If there are problems with the water contact, use soapy water to clean Meridian and dry it thoroughly. Do not use silicone grease on the water contacts!
- Do not clean Meridian with liquids containing solvents.
- Check the battery capacity before each dive.
- If the battery warning appears, replace the battery.
- If any error message appears on the display, take Meridian back to an authorized SCUBAPRO dealer.

6.3 Replacing the battery in Meridian

⚠ WARNING

We recommend having the battery of Meridian replaced by an authorized SCUBAPRO dealer. The change must be made with particular care in order to prevent water from seeping in. The warranty does not cover damages due to an improper replacement of the battery.

Meridian stores the tissue saturation information in non-volatile memory, so the battery can be replaced at any time between dives without loss of information.

👉 NOTE:

- After a dive, Meridian stores tissue desaturation data once an hour while on the surface until it is completely desaturated. If battery is changed while Meridian has remaining desaturation time, the tissue data will not be lost, but Meridian will reference the last stored data set. As a consequence, the data displayed on the surface screen after the battery change (desaturation time, surface interval, no-fly time and CNS O₂) may be different from the values displayed just prior to the battery removal.
- After replacing the battery, you must set the date and time.
- O-ring must be replaced each time when Meridian is opened.



6.4 Warranty

Meridian has a two-year warranty covering defects in workmanship and functioning. The warranty only covers dive computers which have been bought from an authorized SCUBAPRO dealer. Repairs or replacements during the warranty period do not extend the warranty period itself.

Excluded from warranty coverage are faults or defects due to:

- excessive wear and tear
- exterior influences, e.g. transport damage, damage due to bumping and hitting, influences of weather or other natural phenomena
- servicing, repairs or the opening of the dive computer by anybody not authorized to do so by the manufacturer
- pressure tests which do not take place in water
- diving accidents
- improper placement of the battery cap.

For European Union markets, the warranty of this product is governed by European legislation in force in each EU member state.

All warranty claims must be returned with dated proof-of-purchase to an Authorized SCUBAPRO Dealer. Visit www.scubapro.com for the dealer nearest you.

7. GLOSSARY

AVG:	Average depth, calculated from the beginning of the dive or from the time of reset.
CNS O ₂ :	Central Nervous System oxygen toxicity.
DESAT:	Desaturation time. The time needed for the body to completely eliminate any nitrogen taken up during diving.
Dive time:	The time spent below a depth of 0.8m/3ft.
Gas 1, Gas d:	Refers to the main gas (1) and the decompression gas (d) when using the multi gas option of the ZH-L8 ADT MB PMG algorithm.
Local time:	the time in the local time zone.
Max depth:	Maximum depth attained during the dive.
MB:	Microbubble. Microbubbles are tiny bubbles that can build up in a diver's body during and after a dive.
MB level:	One of the six steps, or levels, in SCUBAPRO's customizable algorithm.
MOD:	Maximum Operating Depth. This is the depth at which the partial pressure of oxygen (ppO ₂) reaches the maximum allowed level (ppO ₂ max). Diving deeper than the MOD will expose the diver to unsafe ppO ₂ levels.
Multi gas:	Refers to a dive in which more than one breathing gas is used (air and/or Nitrox).
Nitrox:	A breathing mix made of oxygen and nitrogen, with the oxygen concentration being 22% or higher. In this manual, air is considered as a particular type of Nitrox.
NO FLY:	Minimum amount of time the diver should wait before taking a plane.
No-stop time:	This is the time that a diver can stay at the current depth and still make a direct ascent to the surface without having to perform decompression stops.
O ₂ :	Oxygen.
%O ₂ :	Oxygen concentration used by the dive computer in all calculations.
PDIS:	Profile Dependent Intermediate Stop is an additional deep stop which is suggested by Meridian at depth where 3rd, 4th or 5th compartment starts off gassing.
PMG:	Predictive Multi Gas, refers to the algorithm capable of including up to two different Nitrox mixes in its decompression calculations.
ppO ₂ :	Partial pressure of oxygen. This is the pressure of the oxygen in the breathing mix. It is a function of depth and oxygen concentration. A ppO ₂ higher than 1.6bar is considered dangerous.
ppO ₂ max:	The maximum allowed value for ppO ₂ . Together with the oxygen concentration it defines the MOD.
Press:	The act of pressing and releasing one of the buttons.

Press and hold:	The act of pressing and holding one of the buttons for 1 second before releasing it.
INT.:	Surface interval, the time from the moment the dive is closed.
SOS mode:	The result of having completed a dive without respecting all mandatory decompression obligations.
Stopwatch:	A stopwatch, for example to time certain legs of the dive.
Switch depth:	The depth at which the diver plans to switch to a higher oxygen concentration mix while using the multi gas option in the ZH-L8 ADT MB PMG algorithm.
UTC:	Universal Time Coordinated, refers to time zone changes when traveling.

8. INDEX

Active backlight	27, 44
All-silent mode	13
Altimeter	17
Ascent rate	41
Backlight	27, 44
Battery	43, 53, 54
Bookmarks	32, 43
Buttons	8, 32
Clock settings	11
CNS O ₂	38, 40, 42, 56
Date	11, 13
Desaturation	56
Desaturation reset	25, 37
Dive planner	18
Diving at altitude	34
Flying after diving	35
GAUGE mode	47
Heart rate monitor	29, 50
JavaTRAK	51
Logbook	19, 51
Maintenance	53
MB levels	44
Microbubbles	44, 56
MOD	23, 42, 56
Mountain lakes	34, 35
No-dive warning	36
Nitrox	24, 37, 56
Nitrox reset	24
No-fly time	34
Oxygen concentration	37
Oxygen partial pressure	37
PC interface	51
PMG	38, 56
ppO ₂ max	56
Predictive Multi Gas	see "PMG"
Safety stop timer	26, 43
SOS mode	37, 57
Stopwatch	17
Surface interval	18, 23, 29, 57
Technical information	53
Time of day	8, 16
Time zone	56, 57
Units	26
UTC	12, 57
Wake-up alarm-clock	8
Warning clock	8
Warnings	40, 52
Water contact	28
Water type	27